

TIE0026 series model selection table:

Max. input kV	Model
30	TIE0026PN30
60	TIE0026PN60

Dimensions:mm

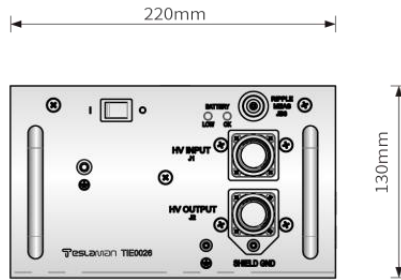

Front View

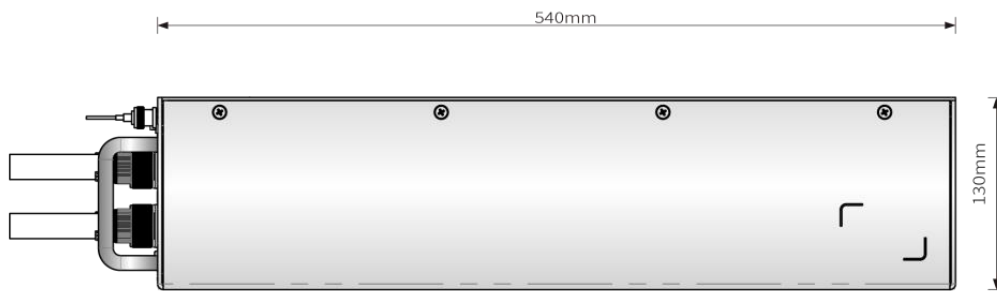

Side View

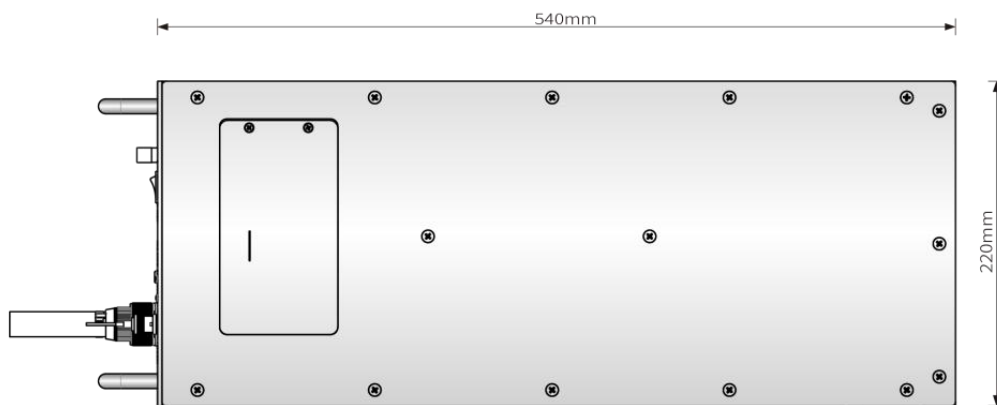

Top View